

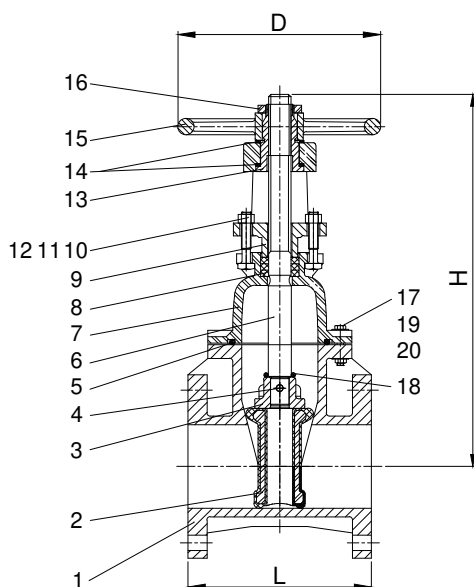

Terminal City Iron Works Ltd.



Dimensions

Size	2"	2.5"	3"	4"
L	7.2"	7.2"	8.0"	9.0"
H(Open)	15.5"	16.5"	19.7"	24.5"
D	7.2"	7.2"	10.0"	10.0"

Size	6"	8"	10"	12"
L	10.5"	11.5"	13.0"	14.0"
H(Open)	31.5"	40.0"	47.5"	57.0"
D	12.0"	14.0"	17.5"	17.5"

Material Specifications

Item	Description	Material	ASTM Spec.
1	Body	Ductile Iron	A536 65-45-12
2	Wedge	EPDM Encapsulated Ductile Iron	A536 65-45-12
3	Wedge Nut	Stainless Steel	AISI 304
4	Pin	Stainless Steel	AISI 304
5	O-ring	Rubber	NBR
6	Stem	Stainless Steel	A276 UNS S30400
7	Bonnet	Ductile Iron	A536 65-45-12
8	Packing	Graphite	Graphite
9	Gland	Ductile Iron	A536 65-45-12
10	Hexagon Head Bolt	Stainless Steel	AISI 304
11	Washer	Stainless Steel	AISI 304
12	Nut	Stainless Steel	AISI 316
13	Stem Nut	Bronze	B148 C95200
14	Thrust Washer	Copper Alloy	B124 C37700
15	Hand Wheel	Ductile Iron	A536 65-45-12
16	Hand Wheel Nut	Ductile Iron	A536 65-45-12
17	Hexagon Head Bolt	Stainless Steel	AISI 304
18	O-ring	Rubber	NBR
19	Washer	Stainless Steel	AISI 304
20	Nut	Stainless Steel	AISI 316



Terminal City Iron Works Ltd.

AWWA C509



Assembly Drawing OS&Y Gate Valve

DRG NO.

3600 Series OS&Y FL x FL

REV

FUSION BONDED EPOXY-NSF 61-AWWA C550